

Right aileron in jammed position

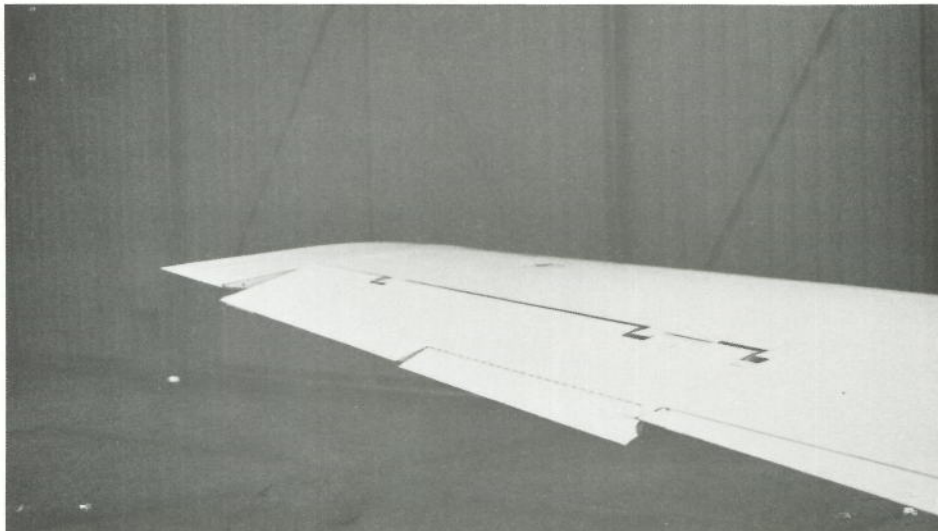

Left aileron in jammed position

G-OEMA jammed aileron positions

DIAGRAMS OF G-OEMA HINGE ARRANGEMENT

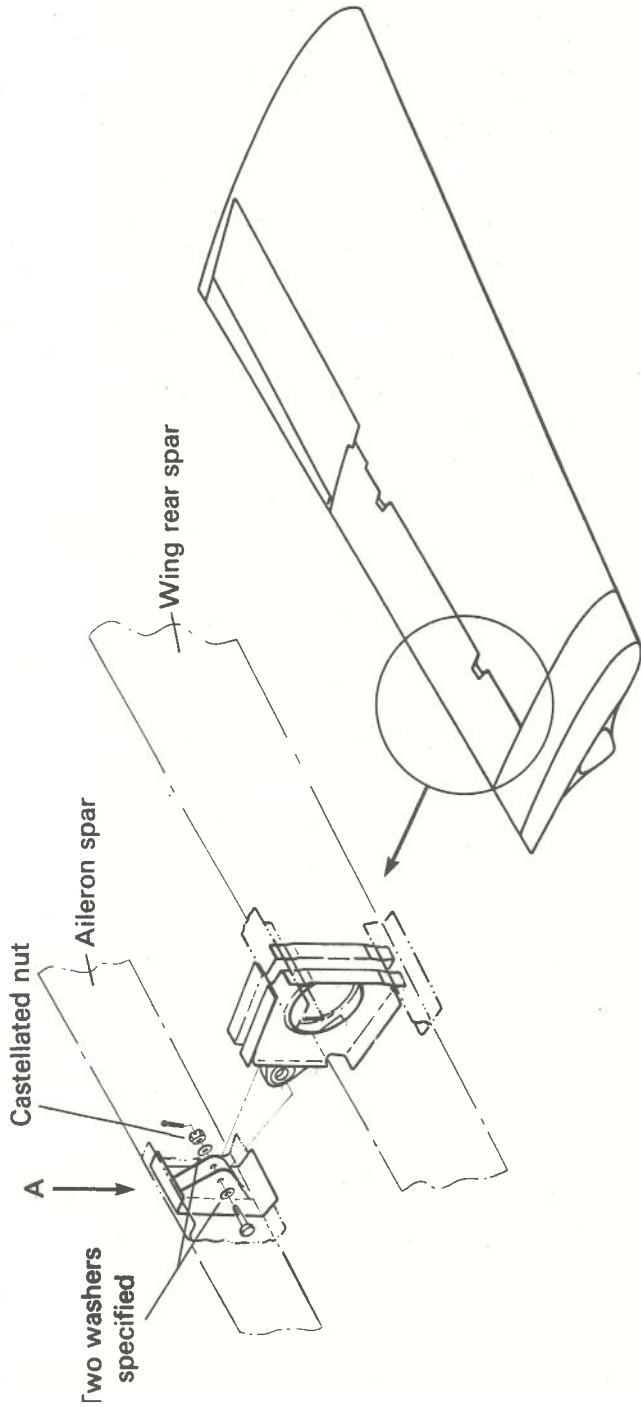

OUTBOARD AILERON HINGE ARRANGEMENT

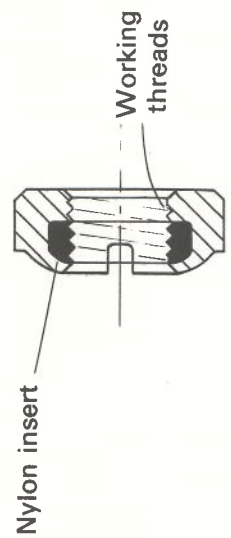
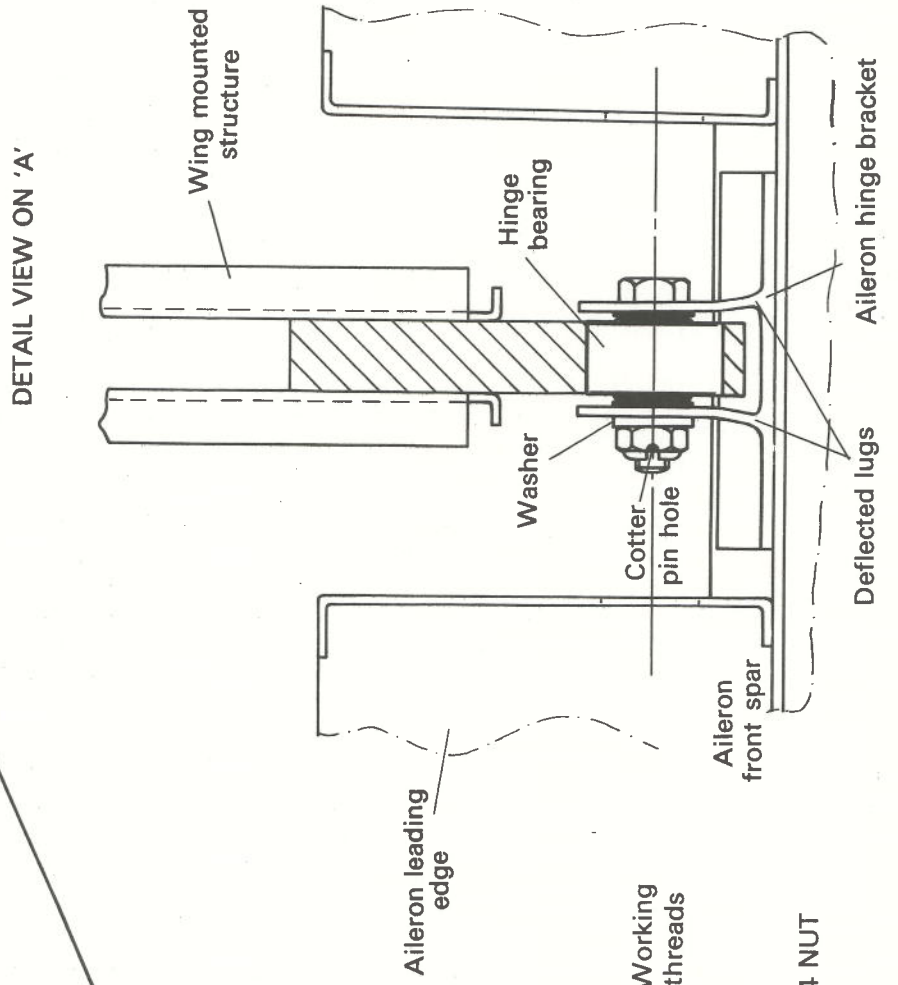

DETAIL SECTION OF MS 17826-4 NUT

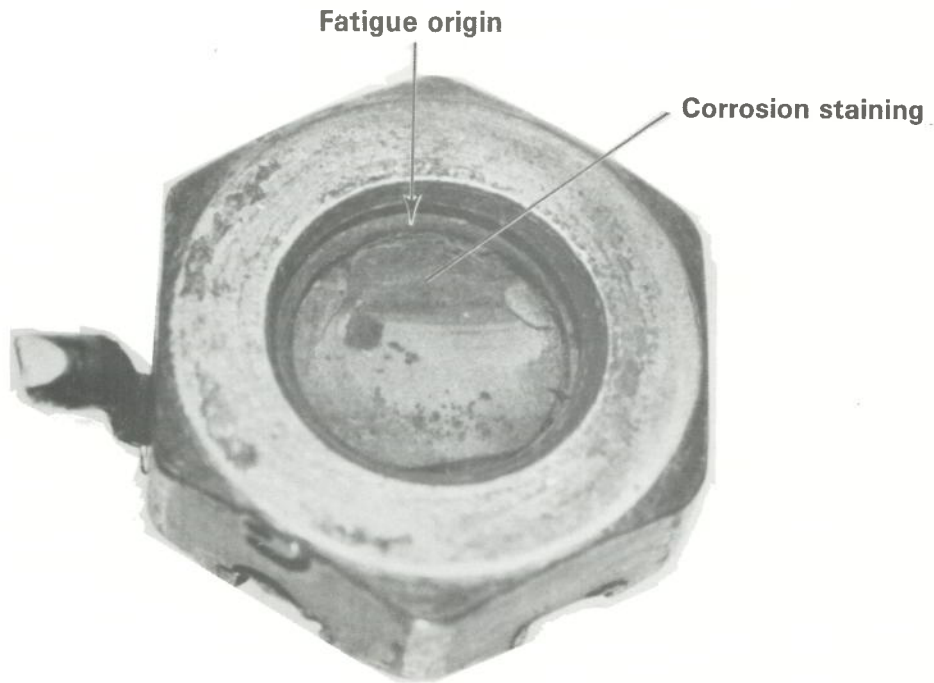

Broken end of bolt contained in nut X6.5

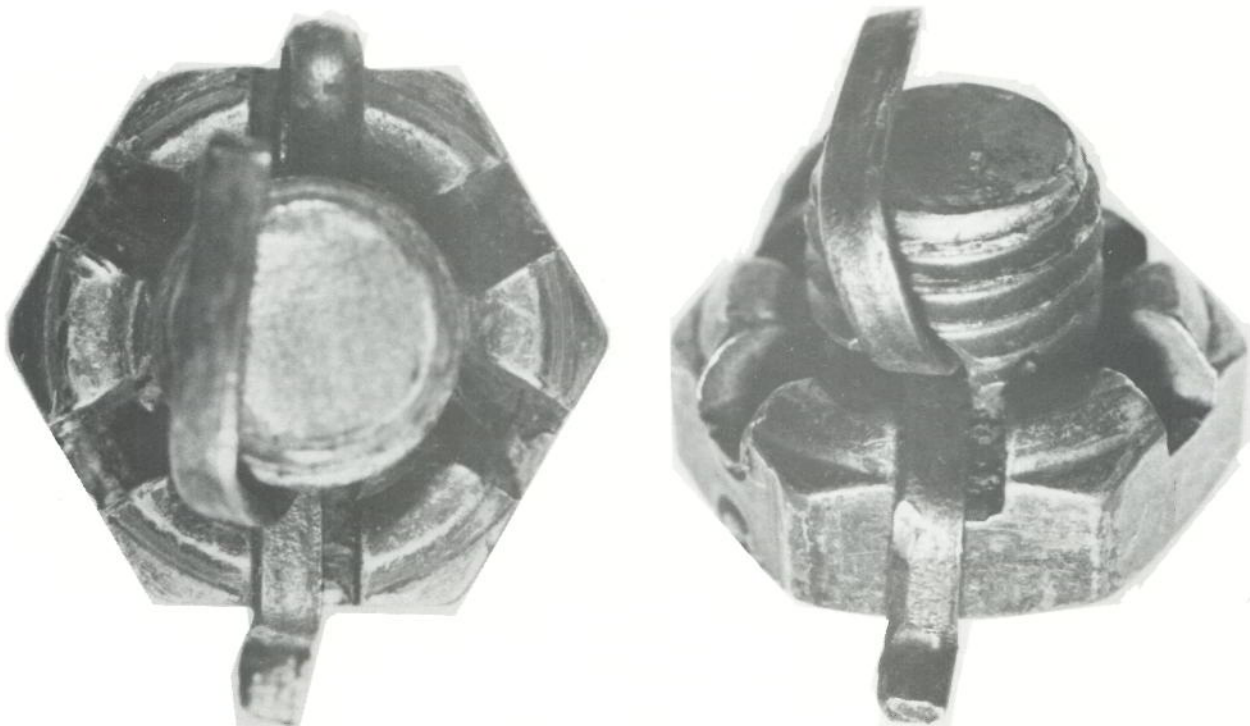

Showing badly aligned cotter pin and castellations X6.5

Broken bolt tail, castellated nut and cotter pin recovered from G-OEMA

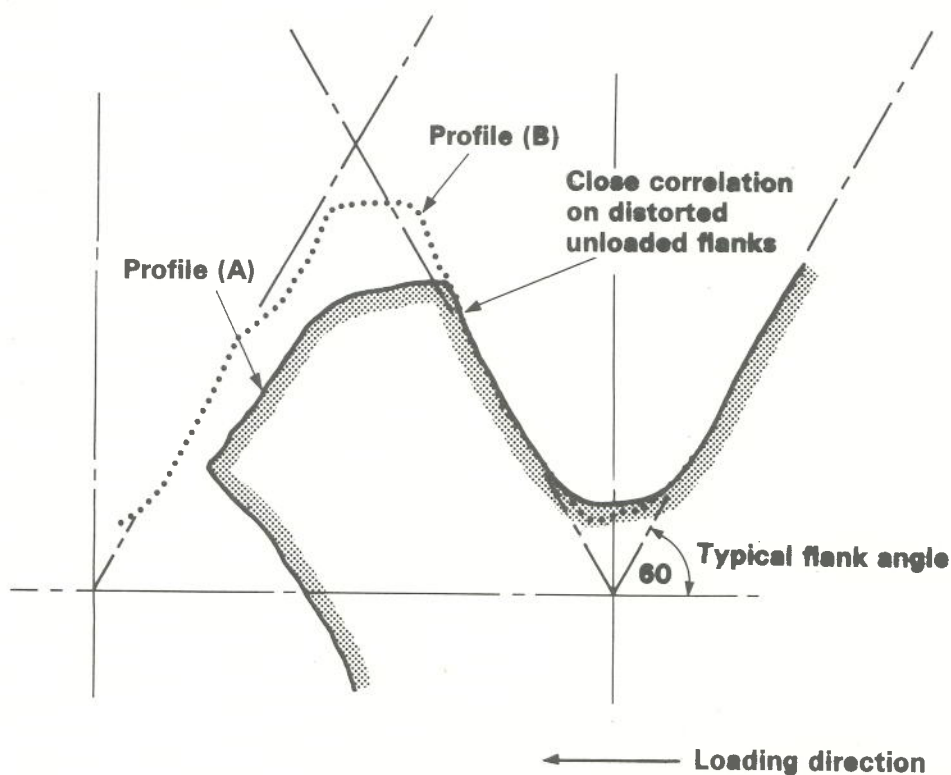
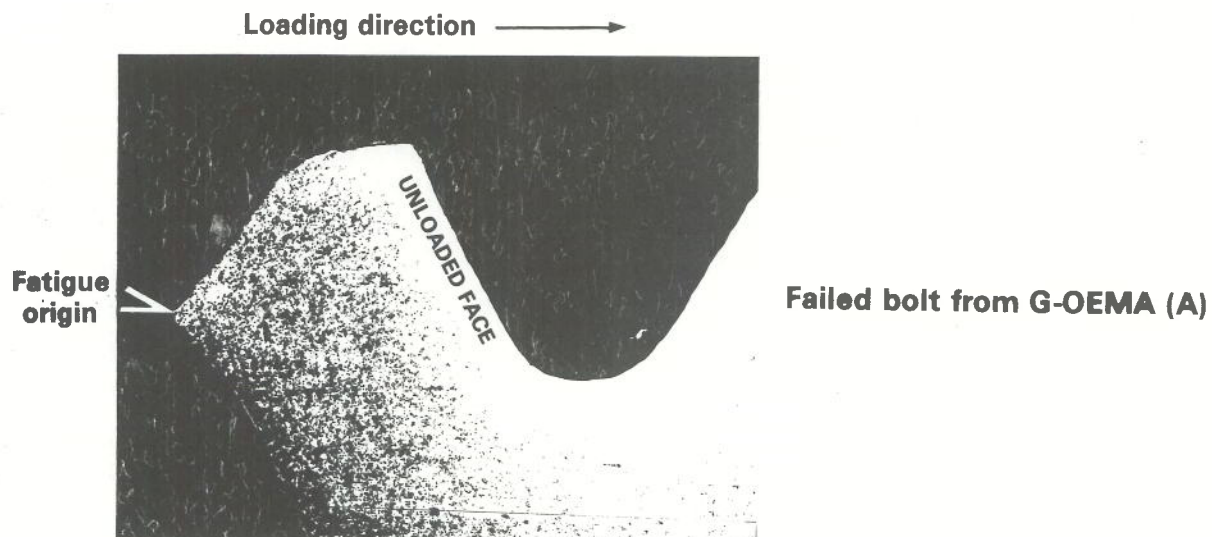

54 lb. ins. test bolt (B)

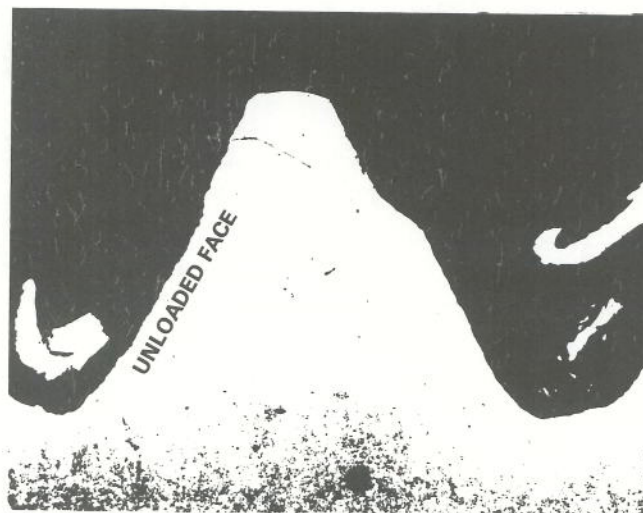

Comparison of thread form damage