

**AAIB Bulletin No:** 8/95      **Ref:** EW/C95/3/6      **Category:** 2.3

**Aircraft Type and Registration:** Schweizer 269C (300C) G-LSLH

**No & Type of Engines:** 1 Avco Lycoming HIO-360-D1A piston engine

**Year of Manufacture:** 1990

**Date & Time (UTC):** 27 March 1995 at 0808 hrs

**Location:** Oxford (Kidlington) Airport

**Type of Flight:** Private (Training)

**Persons on Board:** Crew - 2      Passengers - None

**Injuries:** Crew - None      Passengers - N/A

**Nature of Damage:** Right landing gear skid detached; cabin, tail boom and horizontal stabiliser damaged; main and tail rotor blades severely damaged

**Commander's Licence:** Airline Transport Pilot's Licence (Helicopter) with Instructor Rating

**Commander's Age:** 41 years

**Commander's Flying Experience:** 3,067 hours (of which 95 were on type)  
Last 90 days - 54 hours  
Last 28 days - 52 hours

**Information Source:** AAIB Field Investigation

### **Flight History**

The helicopter was engaged on a training flight with an instructor and an ab initio student on board. The crew was carrying out hovering, takeoffs and landings in a grassed helicopter training area to the west of Runway 02/20 at Oxford Airport. The weather was good; ambient temperature was +3°C and the wind was 15 to 20 kt, gusting to 25 kt, from 350°M and there were no significant obstructions upwind of the training area. The airfield altitude is 270 feet amsl and the aircraft's all-up weight was approximately 1,870 lb, 180 lb below maximum. The training commenced with the student controlling the collective lever and the yaw pedals and the instructor controlling the cyclic stick. With the aircraft hovering into wind the instructor judged that the student was coping well and passed over control of the cyclic. Shortly afterwards the helicopter developed a rapid yaw to the right and the instructor took control and progressively applied full left yaw pedal. This had no noticeable effect and the yawing continued, at an increasing rate. After the aircraft had rotated through about 1½ turns the

instructor attempted to transition forwards but a descent developed and despite the application of full power the right skid struck the ground and the helicopter rolled onto its right side. The instructor closed the fuel shut-off valve with some difficulty, isolating the fuel tanks from the engine but, although the fuel system was undamaged, an appreciable quantity of gasoline spilled overboard from the tanks through the tank vent outlet and from the area of the left tank filler cap as the aircraft lay on its side. There was no fire. Both crew members exited by the cockpit left door, without injury.

## Description

The Hughes Aircraft Corp 269 helicopter design was licensed to Schweizer Aircraft Corp (SAC) in 1983 and bought outright by SAC in 1986 and has since been produced in considerable numbers as the Schweizer 300C, although the official FAA designation is the Schweizer 269C. The helicopter is of conventional layout with seats for two or three occupants side by side and the engine flat mounted beneath the cabin.

Directional control is effected by a tail rotor situated on the left side of the tail boom, driven by a right-angle gearbox at 3,100 RPM at 100% rotor speed and providing a rightward push on the aft end of the tail boom to counteract the torque of the anti-clockwise rotating main rotor, as viewed from above. The tail rotor rotates anti-clockwise viewed from the left, ie upper blade travelling forwards. On this aircraft (Serial No (SN) S1486) it comprised two variable pitch blades mounted on a teetering delta type hub. Yaw pedal displacements were transmitted aft by a mechanical lever/rod and cable/pulley system to a bellcrank pivoted on a bracket attached to the tail rotor gearbox casing. The output end of the bellcrank drove a pitch control assembly located on the tail rotor gearbox output shaft and connected to each tail rotor blade by a pitch link.

The pitch control assembly (PN 269A6050-5) comprised a non-rotating aluminium housing connected via a double row ball bearing to a rotating swashplate assembly splined to the gearbox output shaft (Fig 1). The outer race of the bearing was an interference fit in the housing and secured in it by a swage ring. The bearing inner race was an interference fit on a boss, or shaft, forming an integral part of the aluminium swashplate and was axially clamped against a shoulder formed at the outboard end of the boss by a nut screwed onto a thread formed on the inboard end of the boss. The nut was secured by a lock washer which was fitted between the nut and the inner race and prevented from rotating by a tang that protruded inside the internal diameter and located in a keyway in the boss; thirteen external tangs protruded from the outer diameter of the washer, one of which would be bent into one of eight slots formed in the nut. The inboard end of the pitch control assembly was covered by a non-rotating flexible boot wired to the housing and to the gearbox casing and the outboard end was covered by a rotating boot wired to the swashplate and to the fork assembly carrying the tail rotor blades.

## Aircraft Examination

Inspection of the helicopter showed localised deformation of the right forward part of the cabin, fracture of both attachments for the right landing gear skid, deformation of members of the aircraft main frame on the right and aft side, localised damage to the tail rotor drive shaft, tip damage to the horizontal stabiliser mounted at the right rear of the tail boom, severe deformation of the three main rotor blades and disruption of blade dampers. In addition the tip portion of both tail rotor blades had been damaged, clearly due to contact with the tail stinger, a curved tube fitted beneath the aft end of the tail boom to protect the tail rotor from ground contact. All damage was consistent with the effects of the accident.

AAIB examined the aircraft after partial disassembly of the tail rotor control system. This revealed that the nut in the pitch control assembly on the tail rotor gearbox output shaft had disengaged from the swashplate boss; the nut had not been damaged apart from signs of fretting wear on the face normally bearing against the lock washer, and the boss thread, while damaged, remained intact. The lock washer had been heavily rubbed and considerably distorted and had broken into two major portions with the internal and two external tangs fractured off, one of the latter showing signs of having been bent consistent with engagement with the nut. These components were recovered from within the stationary boot. The swashplate boss showed signs of major fretting and wear; the outer diameter was measured at 1.165-1.175 inches, 0.0166-0.0066 inch below the minimum requirement of 1.1816 inches. The bearing inner race bore was measured at approximately 1.180 inches. The swashplate thus exhibited considerable play within the bearing, both diametrically and in the angular rocking sense, together giving a relative motion of approximately 0.03-0.04 inch at the plane of the pitch link attachment bearings in the swashplate forks. The bearing remained secure within the housing and was apparently undamaged and rotated smoothly and without signs of play or binding. Markings on the component surfaces surrounding the normal position of the lock washer and nut suggested that parts of the lock washer had contacted the swage ring and the exposed bore of the housing inboard of the bearing after the washer had fractured. Other markings suggested washer rotational contact with the bearing inner race and dust cover (non-rotating) and showed that the washer's inner tang had been driven out of the swashplate keyway in a clockwise rotation direction, viewed from outboard. The tail rotor gearbox output shaft was undamaged apart from an area of rubbing adjacent to the gearbox casing, consistent with a period of running with the nut lying on the shaft in this region.

The evidence was consistent with wear of the swashplate boss having allowed the boss to spin within the bearing inner race and with friction loads between the inner race and/or the dust cover and the lock washer having applied a retardation torque to the washer. The boss had a normal right-hand thread and any retardation torque applied to the nut, either via the washer or by direct contact with a slower rotating inner race and/or non-rotating dust cover, would tend to unscrew the nut from the boss. No assessment of the operating timescale over which the major part of the wear had occurred was possible from the component damage.



## Maintenance History

The Maintenance Schedule requires inspection and relubrication of the tail rotor pitch change assembly bearing at 600 operating hours or 2 years' calendar time, necessitating removal and refitment of the swashplate at this interval. This had been carried out on G-LSLH on 8 June 1993 at 458 aircraft hours time since new (TSN). Records showed that G-LSLH had subsequently experienced a previous problem with the assembly; abnormal wear of the splines of the tail rotor gearbox output shaft was noted in June 1994, judged fit for limited continued operation, and around 100 operating hours later, towards the end of 1994 and 13 hours after a 50 Hour Check, play in the swashplate was detected. Inspection reportedly showed that the nut and lock washer were in place but that the preload between the swashplate and the bearing inner race had been lost. The reason for this was not apparent and the parts are no longer available. The bearing was cleaned, found to be satisfactory on inspection, regreased and refitted together with the original housing, but the swashplate dimensions were found to be outside limits and a new item was installed (Part No (PN) 269A6049-003, Batch No G1106892). A new lock washer and new nut (PN MS172242, Batch No G1106892) were also fitted, together with an overhauled tail rotor gearbox (PN 269A5600-701, SN S0014) because of excessive output shaft spline wear on the existing unit (SN S372). The work was completed on 6 January 1995 at 783 hours TSN. The accident occurred 102 operating hours later, at a TSN of 885 hours.

## Maintenance Procedures

The installation of the new swashplate was reportedly carried out as usual in accordance with the Schweizer HMI (Handbook and Maintenance Instruction) manuals. The 269C HMI contains particular information for the 269C but in Section 9, 'Tail Rotor and Control System' generally instructs use of the Basic HMI. This manual (Section 9.8, 'Repair of Tail Rotor and Pitch Control Assembly') refers to HMI Appendix C. The latter notes (Table 9-3 of Section 9.8 of Part VII) that the minimum allowable swashplate shaft outside diameter (OD) is 1.1816 inches and requires inspection for 'Evidence of slippage between inner race of double-row bearing and swashplate', noting that none is allowed. A maximum allowable diameter for the bearing inner race bore is not given; the normal practice of G-LSLH's maintainer was to ensure that the dimensions provided an interference of around 0.0015 inch between the swashplate boss and the bearing inner race.

With regard to refitment of the swashplate in the bearing, HMI Appendix C Part VII, Section 9-13, 'Reassembly of Pitch Control Assembly', requires:

- a 'Install swashplate assembly (3, fig. 9-1) in pitch control housing (6) and secure with new tang washer (2) and locknut (1).
- b Tighten locknut to a torque value of 15-20 foot pounds.'

Fig 9.1 also lists the assembly nut torque as 15-20 ft lb.

A Schweizer Service Information Notice N-163, issued 26 November 1979, provides a procedure for 'seating the double row ball bearing of the tail rotor pitch control assembly, to ensure that the bearing inner race is firmly in contact with the shoulder of the swashplate. At reassembly of the pitch control assembly, the locknut is torqued to 400 to 450 inch-pounds [33-37 ft lb]. Reseating of the bearing inner race and increasing the torque for the locknut is designed to prevent loosening of the locknut and premature wear of the bearing during tail rotor operations.' The procedure requires removal of the locknut and application of a 2,000 lb load to the inner race to press it firmly in contact with the shoulder of the swashplate before refitting the nut and tightening to the higher torque. Incorporation of the procedure was to be signified by addition of a white paint dot to the assembly.

The Notice title described the procedure as applicable to the PN 269A6050 and 369A1800-3 tail rotor pitch control assembly. However, the Models Affected were listed as 'All Model 269A, TH-55A, 269-1 and 269B Helicopters, Model 269C Helicopter Serial No. 0004 thru 0789' and therefore apparently not applicable to G-LSLH (269C SN 1486). The Serial No range listed on the Notice related to the incorporation of the change on the production line with Serial No 0790. Reportedly it had been intended for the revised procedure to be incorporated in the HMI but due to oversight this had not been done and, as described above, the revised procedure thus was not specified for reassembly of the unit during maintenance.

G-LSLH's maintainer had reportedly carried out assembly of the unit for this and other helicopters of the type over a number of years using a manual arbor press to drive the swashplate into the bearing until firm resistance indicated that the bearing inner race was securely seated on the swashplate shoulder before torquing the nut to 15-20 ft lb, as specified by the HMI. Assessment after the accident suggested that the press load used would have been in the order of 160-180 lb, very much less than the 2,000 lb specified by N-163, as well as around only 50% of the nut torque. It was assessed that, whereas a 2,000 lb load would be likely to locally yield the relatively lightweight aluminium swashplate and form the face and radius of the shoulder to the profile of the mating portion of the bearing inner race, a significantly lower pressing load may not achieve this.

### **Previous Cases**

The helicopter manufacturer reported no knowledge of previous similar cases with the S269 helicopter but knew of some cases that had occurred on the Hughes 500, which reportedly uses identical parts for the pitch change assembly. The previous event to G-LSLH (see above) was apparently similar. The only features peculiar to this occurrence and to the accident that could have been of possible relevance appeared to be the pitch change assembly bearing and the tail rotor, but no evidence was found to suggest unusual characteristics for either. The manufacturer attributed some of the previous cases to inadvertent fracture of the lock washer inner tang during assembly due to the washer being dragged round by the nut.



## Crashworthiness

The two fuel tanks located behind the upper part of the cabin are vented into a  $\frac{3}{8}$  inch diameter aluminium pipe attached to the upper surface of each tank near its centre (Fig 2). A tee off this pipe connects to a short upstanding vertical open-ended standpipe with the end curved downwards forming the overboard drain. The vent pipe from the left tank initially loops outwards to just outboard of the left edge of the tank before routing across the helicopter, but that from the right tank passes immediately inboard after connecting to the outlet standpipe (Fig 2). Thus it appears that the configuration will prevent the overboard release of fuel from the

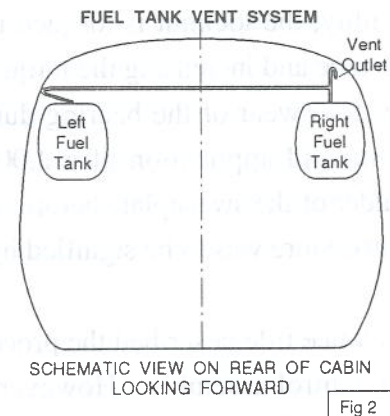

left tank with the aircraft lying on either its left or right side, but will cause the right tank in either case to release overboard through the vent outlet any contents above approximately half full. It appears that such overboard fuel spill in this situation could be prevented by minor reconfiguration of the vent pipe run and outlet.

Examination of the left fuel tank cap showed that a portion of the elastomeric seal was missing. This was last checked during the 50 Hour Check on 24 March 1995, nine operating hours before the accident.

## Summary

The evidence was consistent with the effects of a loss of preload in the attachment of the swashplate to the tail rotor pitch change assembly bearing having allowed fretting wear to occur to the point where the swashplate became loose in the bearing, resulting in further wear. Subsequent relative rotation between the swashplate and the bearing inner race and dust cover caused the lock washer to disengage or fail and the nut to screw off the swashplate. The reason for a loss of preload could not be positively established but the assembly technique used by the maintainer, while in accordance with the HMI, did not include the procedure specified by Schweizer Notice N-163 published in 1979 for seating the swashplate in the bearing with a 2,000 lb press load that was likely to be much higher than that used if following the HMI procedure, together with an approximate doubling of the nut torque load. This procedure was not listed as applicable to G-LSLH's Serial No, as the change had been incorporated on the production line, and due to an oversight had not been incorporated in the HMI. The rate of progression of the failure could not be positively established but the previous occurrence to G-LSLH suggested that noticeable play in the assembly may be present for some period before disconnection occurs.

The fuel tank vent system configuration and a previously damaged tank filler cap seal allowed considerable quantities of gasoline to spill overboard after the aircraft rolled onto its side, although the fuel system was undamaged and the fuel selector was turned off.

### **Safety Recommendations**

In view of the findings AAIB made the following recommendations on 24 July 1995:

#### **Safety Recommendation 95-11**

It is recommended that for UK registered Schweizer 269 helicopters that the CAA:

- 1 Liaise with the manufacturer to confirm the assembly procedure necessary to ensure a satisfactory installation of the tail rotor pitch change assembly.
- 2 Consider the implementation of a disassembly inspection of the tail rotor pitch change assembly for excessive wear and reassembly in accordance with the necessary procedure.
- 3 Consider the implementation of a suitable inspection of the tail rotor pitch change assembly for excessive play before each flight until the inspection and reassembly recommended in 2 has been carried out.

#### **Safety Recommendation 95-12**

It is recommended that for UK registered Schweizer 269 helicopters, to prevent overboard release of fuel after an accident where the helicopter comes to rest on its side but the fuel system remains undamaged, the CAA consider the need for:

- 1 Reconfiguration of the fuel tank vent system to prevent fuel release through the vent outlet.
- 2 Measures aimed at ensuring the integrity of fuel tank filler cap seals.

# SCHWEIZER 269C TAIL ROTOR PITCH CHANGE ASSEMBLY

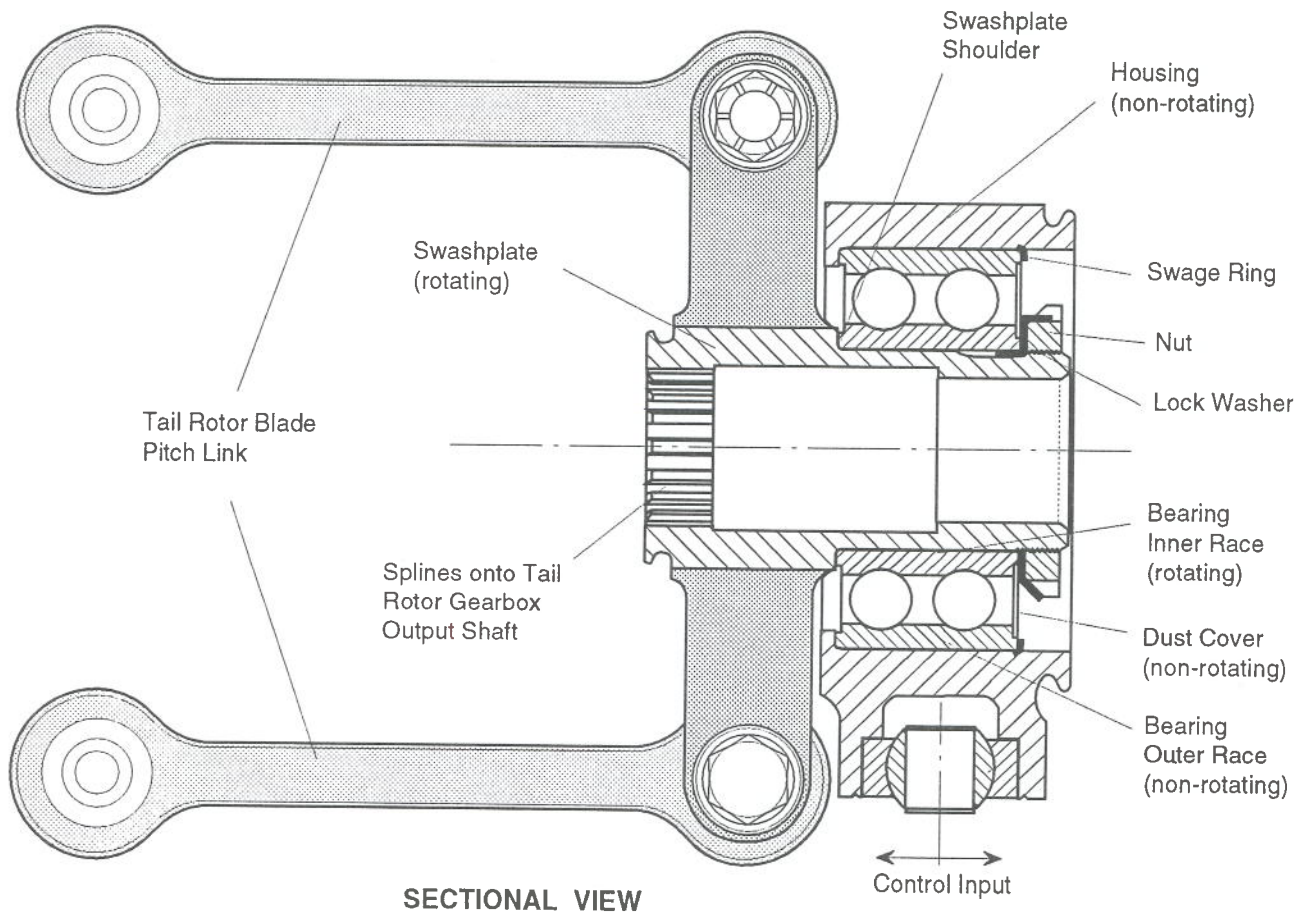
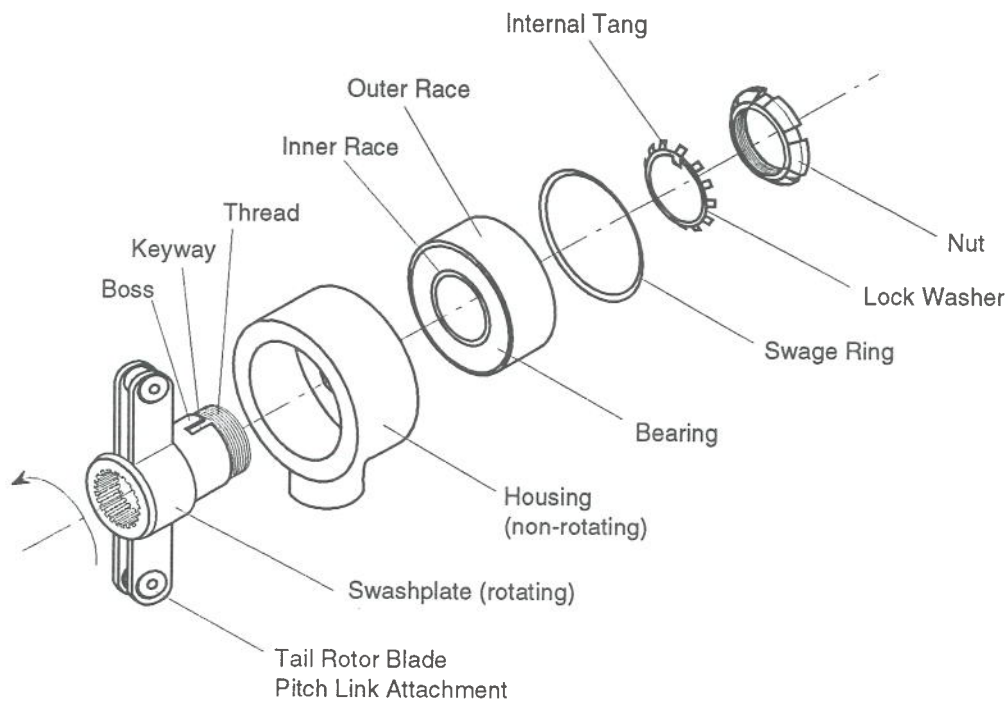

Fig 1